

- ① HOUSING: BLACK POLYESTER, UL 94V-0 RATED;
 CONTACTS: BRASS
 SHELLS: CARBON STEEL
 SCREWLOCK: ZINC
 INSERTS: BRASS
- ② GOLD PLATED FOR LENGTH OF 3.81 [.150] MIN FROM MATING END, GOLD FLASH IN MATED AREA, 2.54μm [.000100] MIN TIN OR TIN-LEAD FOR A LENGTH OF DIMENSION A FROM OPPOSITE END, BOTH OVER 1.27μm [.000050] MIN NICKEL.
- ③ GOLD PLATED FOR LENGTH OF 3.81 [.150] MIN FROM MATING END, 0.76μm [.000030] MIN GOLD IN MATED AREA, 2.54μm [.000100] MIN TIN OR TIN-LEAD FOR A LENGTH OF DIMENSION A FROM OPPOSITE END, BOTH OVER 1.27μm [.000050] MIN NICKEL.
 -OR-
 GOLD FLASH OVER PALLADIUM NICKEL PLATED FOR A LENGTH OF 3.81 [.150] MIN FROM MATING END, 0.76μm [.000030] MIN GOLD IN MATED AREA, 2.54μm [.000100] MIN TIN OR TIN-LEAD FOR A LENGTH OF DIMENSION A FROM OPPOSITE END, BOTH OVER 1.27μm [.000050] MIN NICKEL.
- ④ SHELLS: 5.08μm [.000200] MIN TIN OVER 2.54μm [.000100] MIN COPPER
 CONTACTS: SEE TABLE.
- ⑤ DATUMS AND BASIC DIMENSIONS ESTABLISHED BY CUSTOMER.
- ⑥ 2.79[.110] MAX IN SHELL TAB CLINCH AREAS.

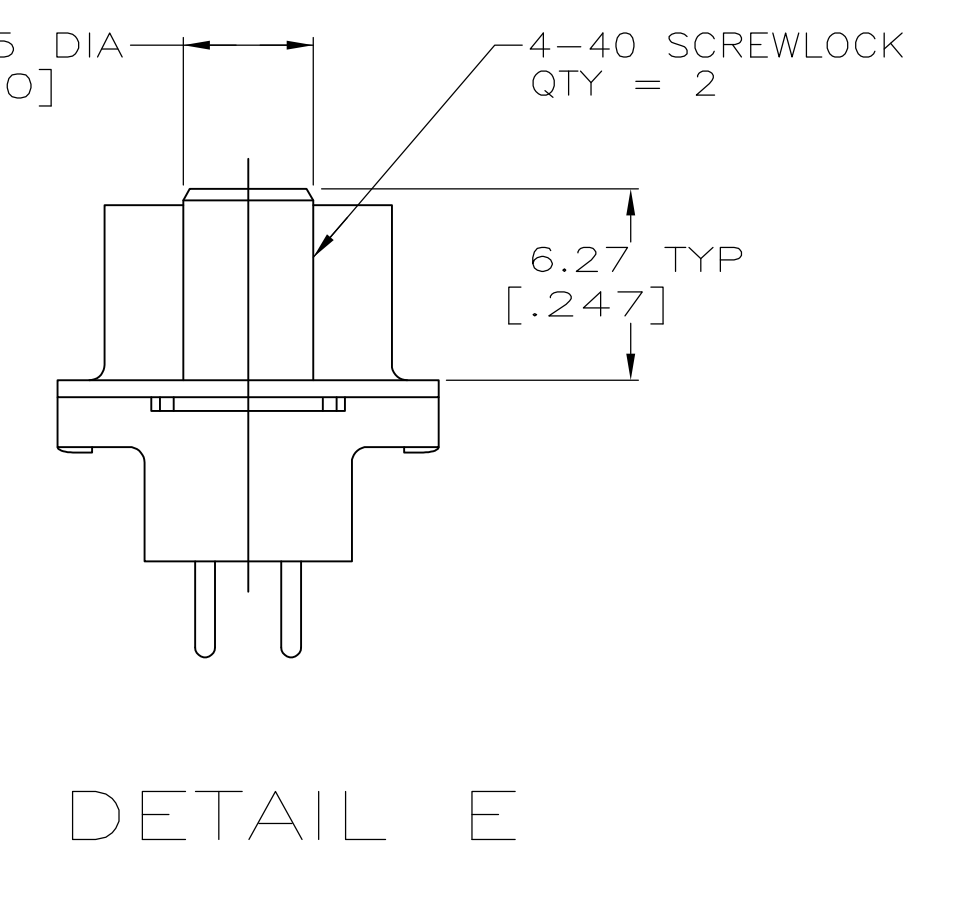

DETAIL D

DETAIL E

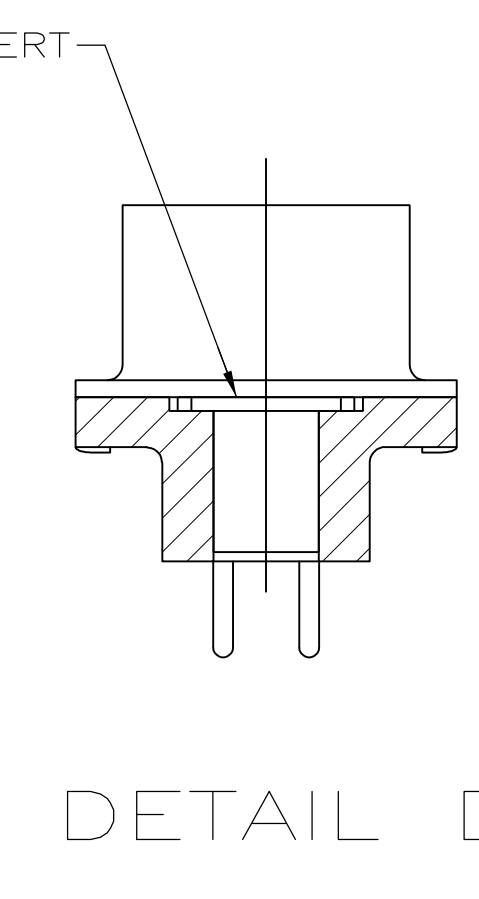
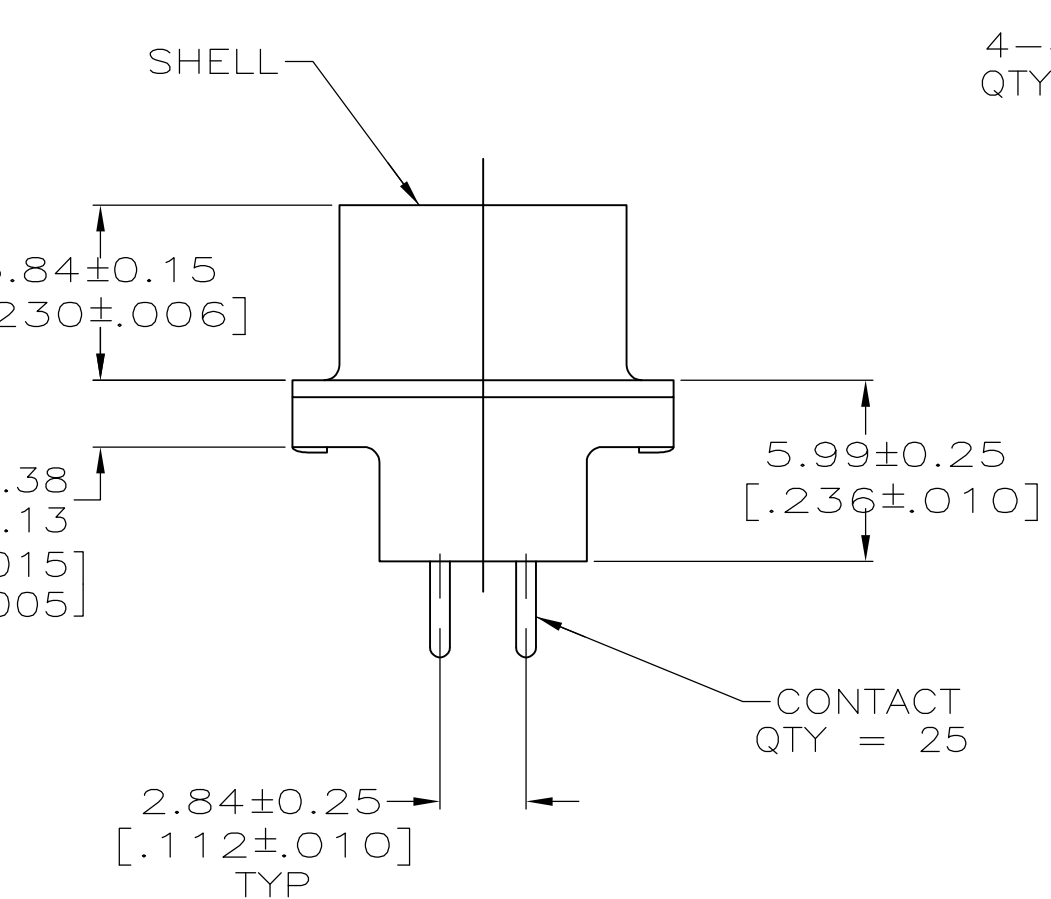
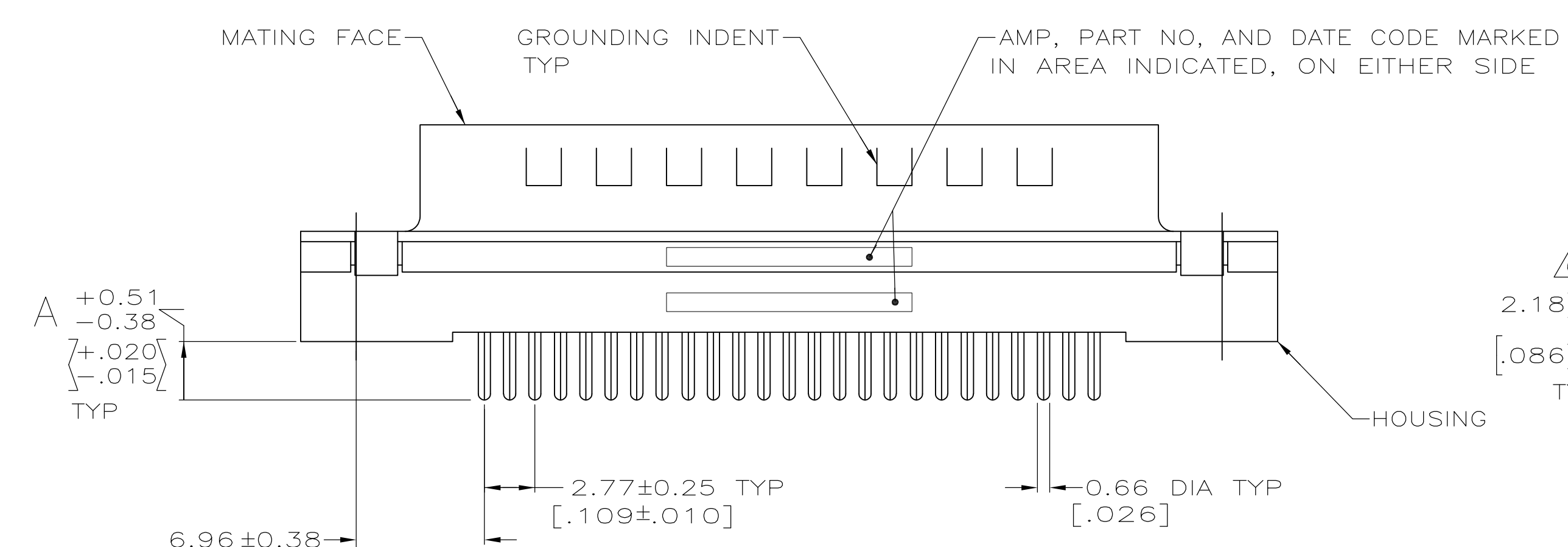
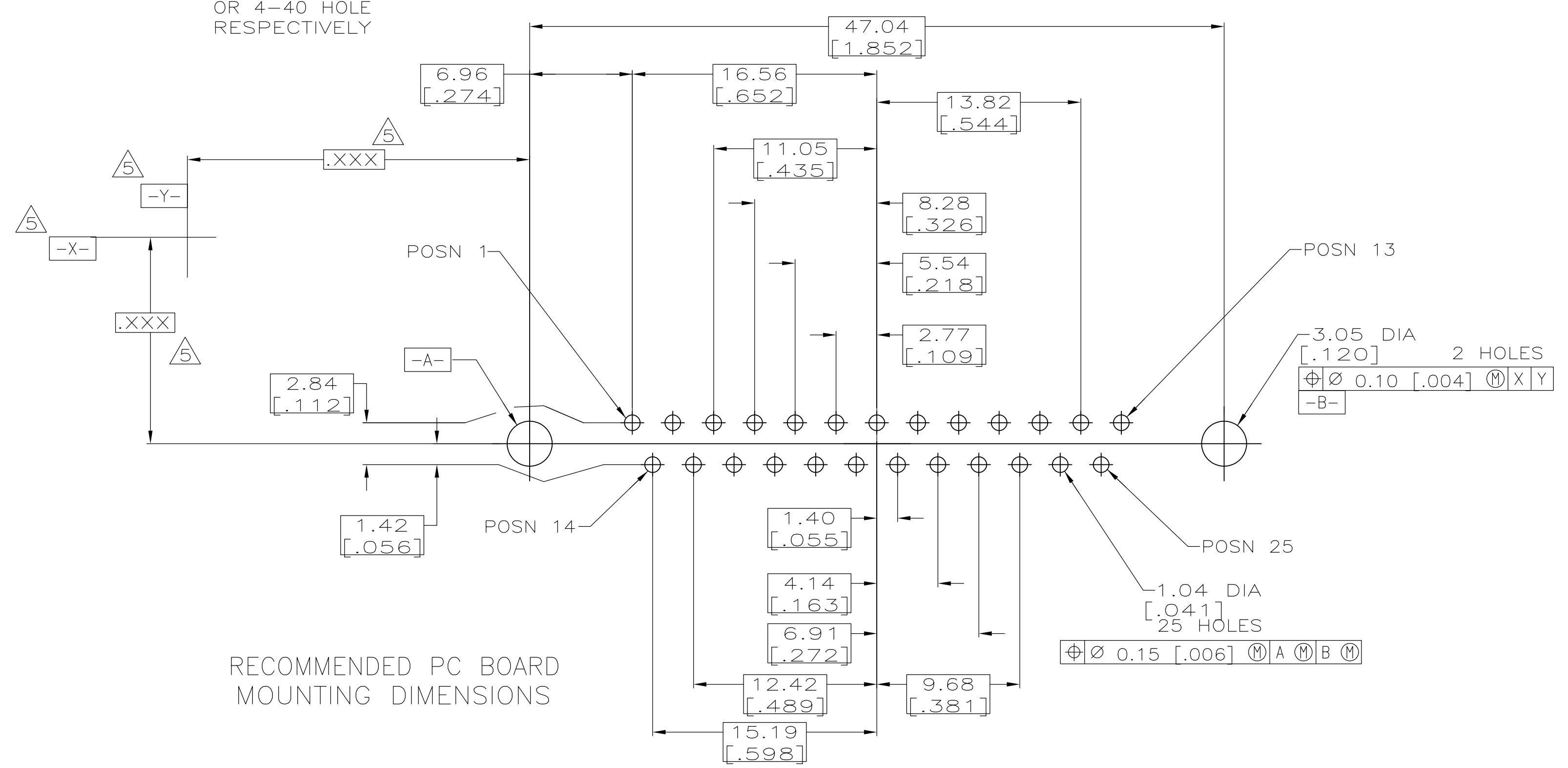

RECOMMENDED PC BOARD MOUNTING DIMENSIONS

OBSOLETE	6.35 [.250]	4-40 SCREWLOCK (DETAIL E)	③	1-745968-8
OBSOLETE	6.35 [.250]	4-40 SCREWLOCK (DETAIL E)	②	1-745968-7
OBSOLETE	4.32 [.170]	4-40 SCREWLOCK (DETAIL E)	③	1-745968-6
OBSOLETE	4.32 [.170]	4-40 SCREWLOCK (DETAIL E)	②	1-745968-5
	3.18 [.125]	4-40 SCREWLOCK (DETAIL E)	③	1-745968-4
OBSOLETE	3.18 [.125]	4-40 SCREWLOCK (DETAIL E)	②	1-745968-3
	6.35 [.250]	4-40 INSERT (DETAIL D)	③	1-745968-2
OBSOLETE	6.35 [.250]	4-40 INSERT (DETAIL D)	②	1-745968-1
	4.32 [.170]	4-40 INSERT (DETAIL D)	④	1-745968-0
	4.32 [.170]	4-40 INSERT (DETAIL D)	②	745968-9
	3.18 [.125]	4-40 INSERT (DETAIL D)	③	745968-8
	3.18 [.125]	4-40 INSERT (DETAIL D)	②	745968-7
OBSOLETE	6.35 [.250]	-	③	745968-6
	6.35 [.250]	-	②	745968-5
	4.32 [.170]	-	③	745968-4
SUPERSEDED BY 745968-4	4.32 [.170]	-	②	745968-3
	3.18 [.125]	-	③	745968-2
SUPERSEDED BY 745968-2	3.18 [.125]	-	②	745968-1

THIS DRAWING IS A CONTROLLED DOCUMENT.		DIN J. McCLINTON 12/01/89		Tyco Electronics Corporation	
DIMENSIONS: mm [INCHES]		CIR R. STONE 02/01/90		Harrisburg, PA 17105-3608	
TOLERANCES UNLESS OTHERWISE SPECIFIED:		APVD G. ROHDE 2-02-90		NAME	
0 PLC	±	PRODUCT SPEC		PLUG ASSEMBLY, SIZE 3, 25 POSITION, VERTICAL, FRONT METAL SHELL, AMPLIMITE® HD-20	
1 PLC	±	APPLICATION SPEC		108-40025	
2 PLC	± 0.13 [.005]	SIZE		A1	
3 PLC	±	CAGE CODE		DRAWING NO. 00779	
4 PLC	±	WEIGHT		745968	
ANGLES	±	CUSTOMER DRAWING		SCALE 4:1 SHEET 1 OF 1 REV P	